

BUILDING #328

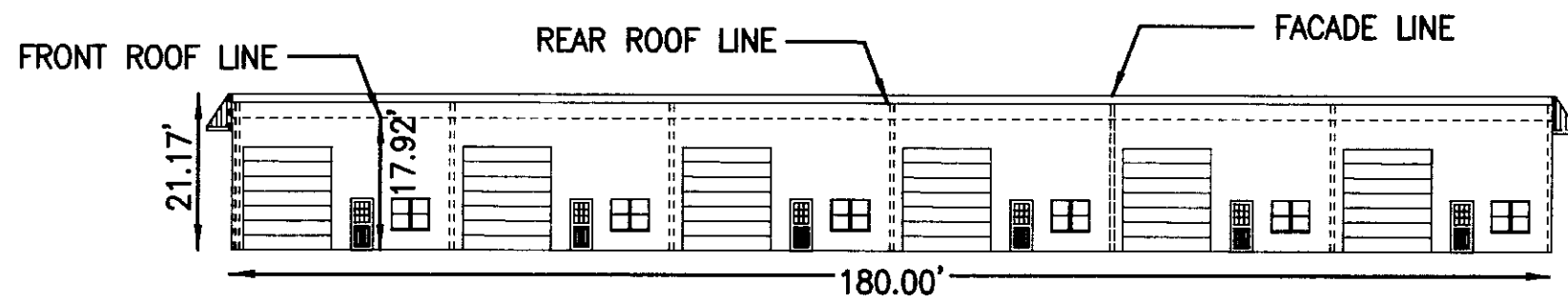

FRONT VIEW

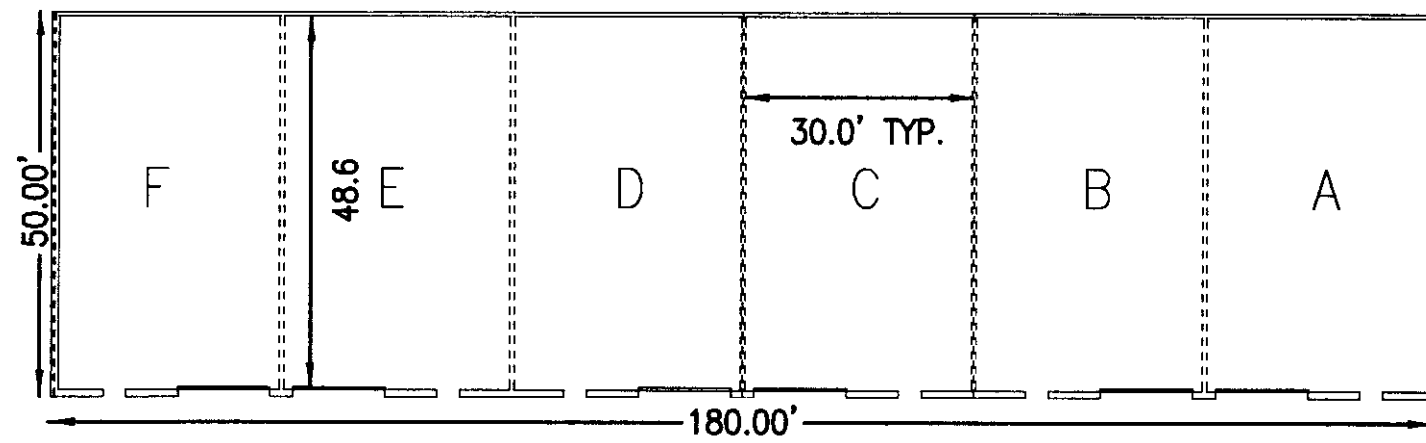
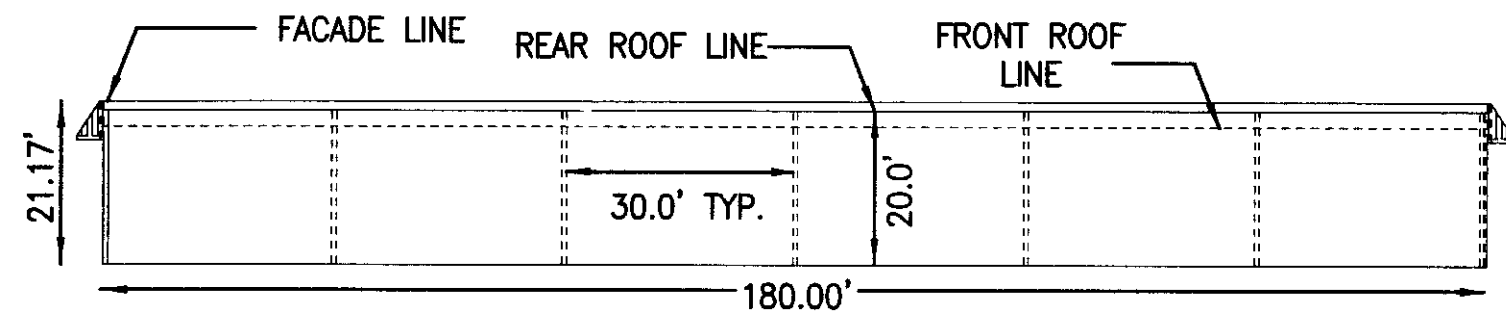

REAR VIEW

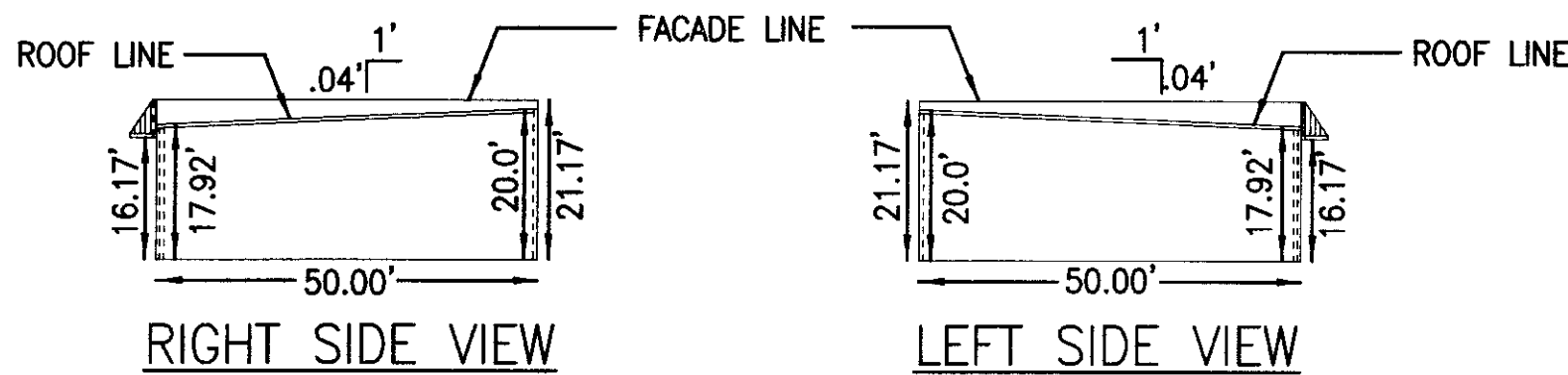

RIGHT SIDE VIEW

LEFT SIDE VIEW

ALL BUILDING DIMENSIONS ARE IN FEET

I CERTIFY THAT THESE PLANS ARE ACCURATE AND COMPLIES WITH THE PROVISIONS OF SECTION 55-79.58(b) OF THE CODE OF VIRGINIA OF 1950 AS AMENDED AND ALL UNITS SHOWN HEREON HAVE BEEN SUBSTANTIALLY COMPLETED.



EXHIBIT "C"
PLAT OF
YORKTOWN COMMERCE CENTER
A CONDOMINIUM
PHASE 1

YORKTOWN, VIRGINIA
NELSON MAGISTERIAL DISTRICT

scale 25 0 25 50
SCALE: 1"=25' feet

DATE: 6/06/08 JOB# 1937.2-08



ENGINEERING SURVEYING
1500 BREEZEPORT WAY SUITE 400
SUFFOLK, VIRGINIA 23435
Office: 757.686.3345 Fax: 757.686.3348
SHEET: 4 of 4

APPROVED:
YORK COUNTY BOARD OF SUPERVISORS

BY: Al Maddalena
PLAT APPROVING AGENT

DATE: 9/4/08

STATE OF VIRGINIA
COUNTY OF YORK
IN THE CLERK'S OFFICE OF THE CIRCUIT COURT FOR THE
COUNTY OF YORK-POQUOSON THIS 10th DAY OF Sept. 2008,
THIS PLAT WAS PRESENTED AND ADMITTED TO RECORD AS
THE LAW DIRECTS AS INSTRUMENT NO. 0800 2121 8 10:21 AM

TESTE: Lynn S. Mendibur
CLERK
BY: Valerie Lynn Baldwin D.C.

2008 SEP 10 AM 10:21