

**EXHIBIT "C"**  
 PLAT OF  
**RAINBROOK VILLAS**  
 A CONDOMINIUM (INSTR. #020005988)  
**PHASE XXV**  
 SHEET 2 OF 4

GRAFTON DISTRICT - COUNTY OF YORK, VIRGINIA  
 SCALE: 1" = 100' DECEMBER 4, 2003  
 0 50 100 200 300 400 FEET  
 GRAPHIC SCALE

**THE SIRINE GROUP, LTD.**  
 SURVEYORS • ENGINEERS • PLANNERS  
 4794 GEORGE WASHINGTON MEMORIAL HIGHWAY  
 U.S. ROUTE 17  
 P.O. BOX 450  
 WHITE MARSH, VIRGINIA 23183

**OWNER'S CONSENT**  
 THE PLATTING OF THE CONDOMINIUM SHOWN HEREON IS IN ACCORDANCE WITH THE DESIRES OF THE UNDERSIGNED OWNERS AND PROPRIETORS.  
 RAINBROOK VILLAS, L.L.C.,  
 A VIRGINIA LIMITED LIABILITY COMPANY  
 BY: VILLA DEVELOPMENT, L.L.C.,  
 A VIRGINIA LIMITED LIABILITY COMPANY  
 SOLE MEMBER

BY: Louise M. Spence DATE: December 19, 2003  
 MEMBER

COMMONWEALTH OF VIRGINIA  
 COUNTY OF YORK, TO WIT:

THE FOREGOING INSTRUMENT WAS ACKNOWLEDGED BEFORE ME THIS 19th DAY OF December, 2003, BY Louise M. Spence, Sr. MEMBER OF VILLA DEVELOPMENT, L.L.C., A VIRGINIA LIMITED LIABILITY COMPANY, SOLE MEMBER OF RAINBROOK VILLAS, L.L.C., A VIRGINIA LIMITED LIABILITY COMPANY.  
 MY COMMISSION EXPIRES: 6-30-05

NOTARY PUBLIC

**SURVEYOR'S CERTIFICATE**

TO THE BEST OF MY KNOWLEDGE AND BELIEF ALL THE REQUIREMENTS AS SET FORTH IN THE ORDINANCE FOR APPROVING PLATS IN THE COUNTY OF YORK, VIRGINIA, HAVE BEEN COMPLIED WITH, INCLUDING A CLOSURE OF NOT LESS THAN 1'/20,000'.

THIS IS TO CERTIFY THAT THE LAND EMBRACED WITHIN THE LIMITS OF THIS CONDOMINIUM IS IN THE NAME OF RAINBROOK VILLAS, L.L.C., AS RECORDED IN THE CERTIFICATE OF AMENDMENT DATED AUGUST 13, 1999, RECORDED IN DEED BOOK 1126, PAGE 324 AND WAS ACQUIRED FROM ROBERT E. BENDL AND GLORIA M. BENDL BY DEED DATED MAY 19, 1999 AND RECORDED IN DEED BOOK 1099, PAGE 72 AND FROM VILLA DEVELOPMENT, L.L.C., A VIRGINIA LIMITED LIABILITY COMPANY BY DEED DATED JUNE 9, 1999 AND RECORDED IN DEED BOOK 1099, PAGE 70 AND FROM RAINBROOK SOUTH, L.L.C. AS RECORDED IN THE DEED IN DISSOLUTION DATED MARCH 22, 2002 RECORDED AS INSTRUMENT NUMBER 020004987 IN THE CLERK'S OFFICE OF THE CIRCUIT COURT FOR YORK COUNTY, VIRGINIA. I CERTIFY THAT THE MONUMENTS AND IRON PINS AS SHOWN ON THIS PLAT WILL BE SET ON OR BEFORE DECEMBER 31, 2003. I CERTIFY THAT THIS PLAT IS ACCURATE AND COMPLIES WITH THE PROVISIONS OF SECTION 55-79.58(a) OF THE CODE OF VIRGINIA OF 1950 AS AMENDED AND ALL UNITS SHOWN HEREON HAVE BEEN SUBSTANTIALLY COMPLETED.

SIGNED: James S. Leigh  
 JAMES S. LEIGH, L.S. # 1758

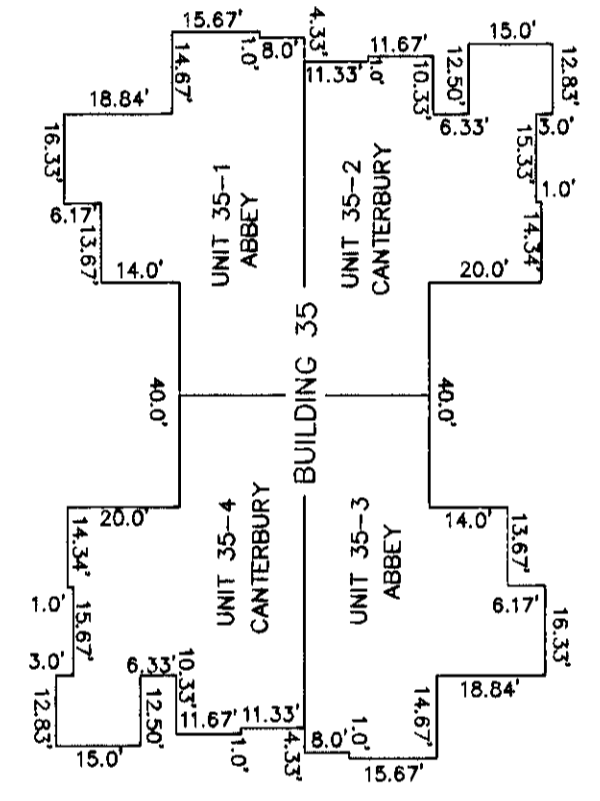
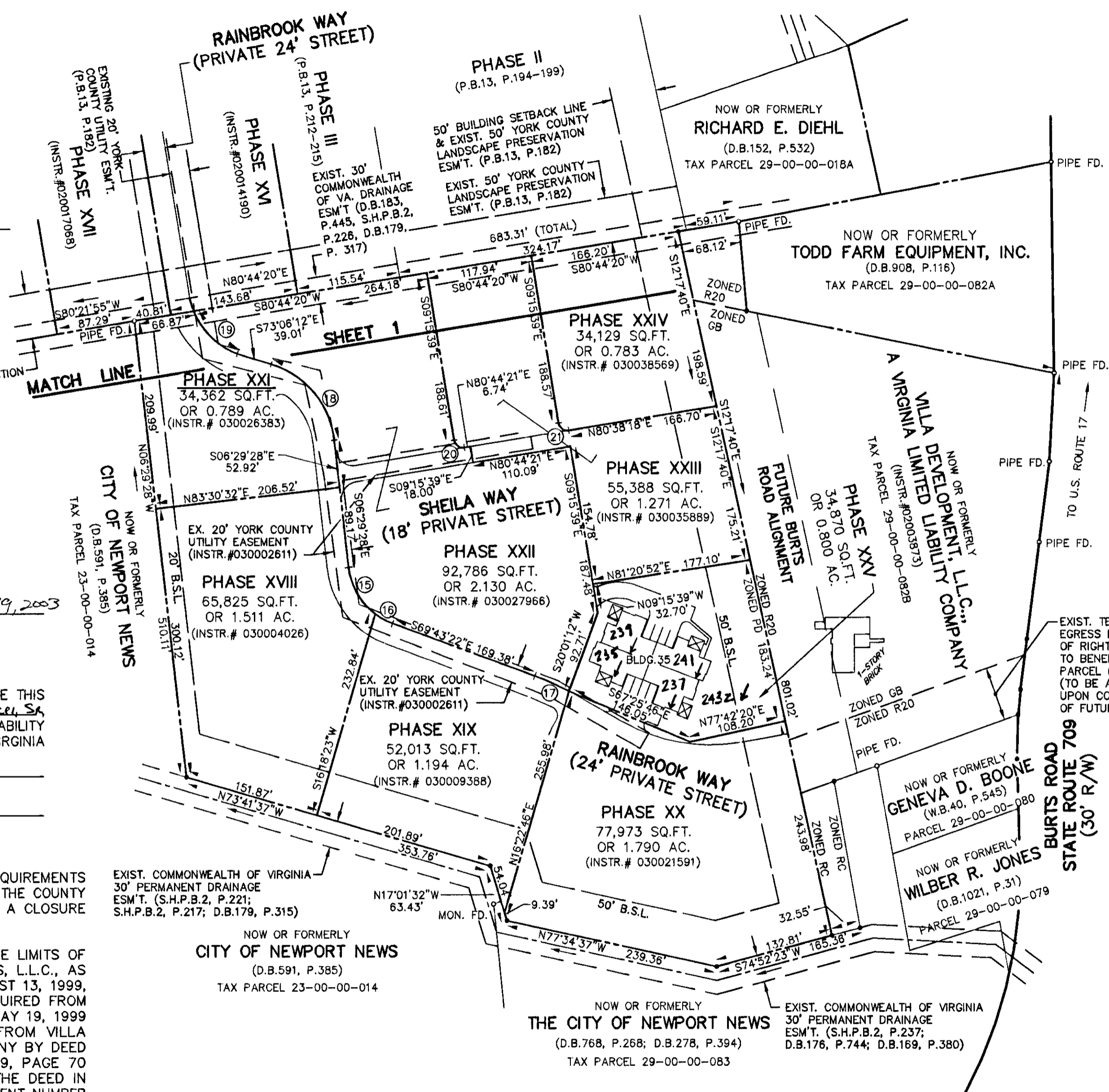
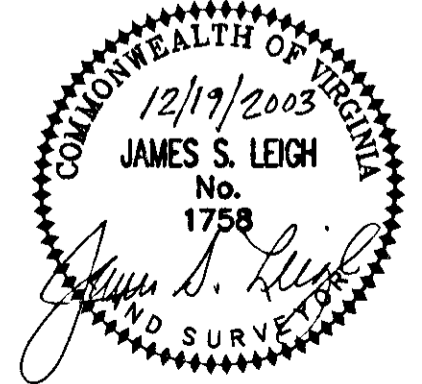

APPROVED:  
 YORK COUNTY BOARD OF SUPERVISORS  
 BY: [Signature]  
 DATE: 12/23/03

STATE OF VIRGINIA  
 COUNTY OF YORK  
 IN THE CLERK'S OFFICE OF THE CIRCUIT COURT FOR THE COUNTY OF YORK, VIRGINIA, THE 23rd DAY OF December, 2003, THIS PLAT WAS PRESENTED AND ADMITTED TO RECORD AS THE LAW DIRECTS AS INSTRUMENT NUMBER:

030039913  
 TESTE: Lynn S. Jenkins CLERK  
 BY: [Signature] DEPUTY CLERK

PROPERTY IS ASSESSOR'S PARCEL 29-00-00-018B  
 GPIN: S06C-0943-2132