

**DENNIS DRIVE**  
40' R/W

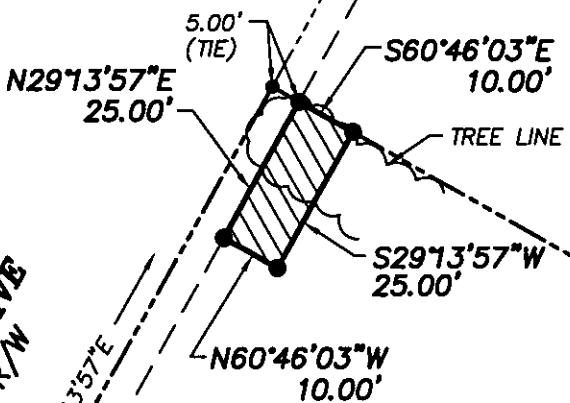

NOW OR FORMERLY  
GREGORY K. MORGAN ETUX  
D.B. 919, PG. 281  
#159 DENNIS DRIVE

NOW OR FORMERLY  
GARY L. VINSON ETUX  
GPIN: G15A-0991-4402  
D.B. 1103, PG. 748  
#157 DENNIS DRIVE

**LEGEND**

- IPF (IRON PIPE FOUND)
- IRF (IRON ROD FOUND)
- CMF (CONC MON FOUND)
- DENOTES PERMANENT UTILITY EASEMENT  
HEREBY CONVEYED TO YORK COUNTY  
250 S.F.

**NOTES:**

1. HORIZONTAL COORDINATE INFORMATION IS BASED ON THE VIRGINIA STATE PLANE COORDINATE SYSTEM SOUTH ZONE (NAD 83), UNITS ARE U.S. SURVEY FEET, CONTROL INFORMATION PROVIDED BY URS CORPORATION.
2. THIS PLAT IS FOR EASEMENT PURPOSES ONLY AND DOES NOT CONSTITUTE A PHYSICAL OR BOUNDARY SURVEY.
3. TOPOGRAPHIC AND PROPERTY LINE INFORMATION, IF SHOWN, WAS PROVIDED BY URS CORPORATION.

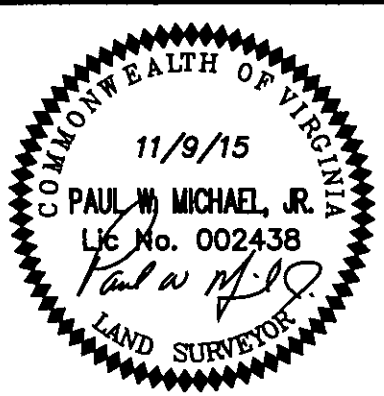

References:  
D.B.1103, PG.748

Notes:

**PLAT OF EASEMENT**  
**FROM: GARY L. VINSON ETUX**

**TO: COUNTY OF YORK**  
**PROJECT: QUEENS LAKE SEWER PROJECT**

DATE: 11/9/15    Scale: 1'=30'    Job No.: 07-059



**MICHAEL SURVEYING & MAPPING, P.C.**  
41 OLD OYSTER POINT RD. - SUITE B  
NEWPORT NEWS, VIRGINIA 23602  
TEL 757.873.1762 FAX 757.873.1772